

CARE-based fusion

Marcos Serrano
Laurence Nigay

University of Grenoble, France
Laboratory of Informatics of Grenoble – LIG
Engineering Human-Computer Interaction Group

Fusion

- Input multimodal interaction
- Late fusion based on temporal relationships
- Combination space of multimodal interaction
 1. Temporal relationships between modalities
 - Allen's properties

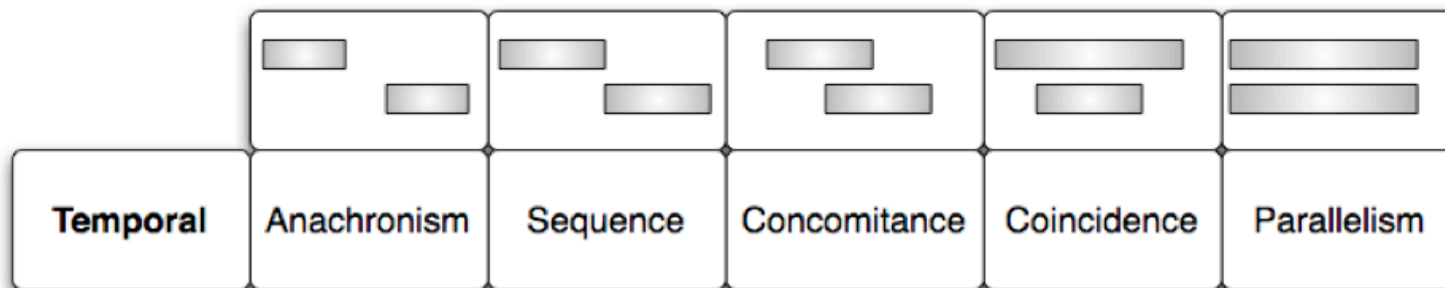

2. CARE properties

CARE

Complementarity Assignment Redundancy Equivalence

- Relationships between modalities

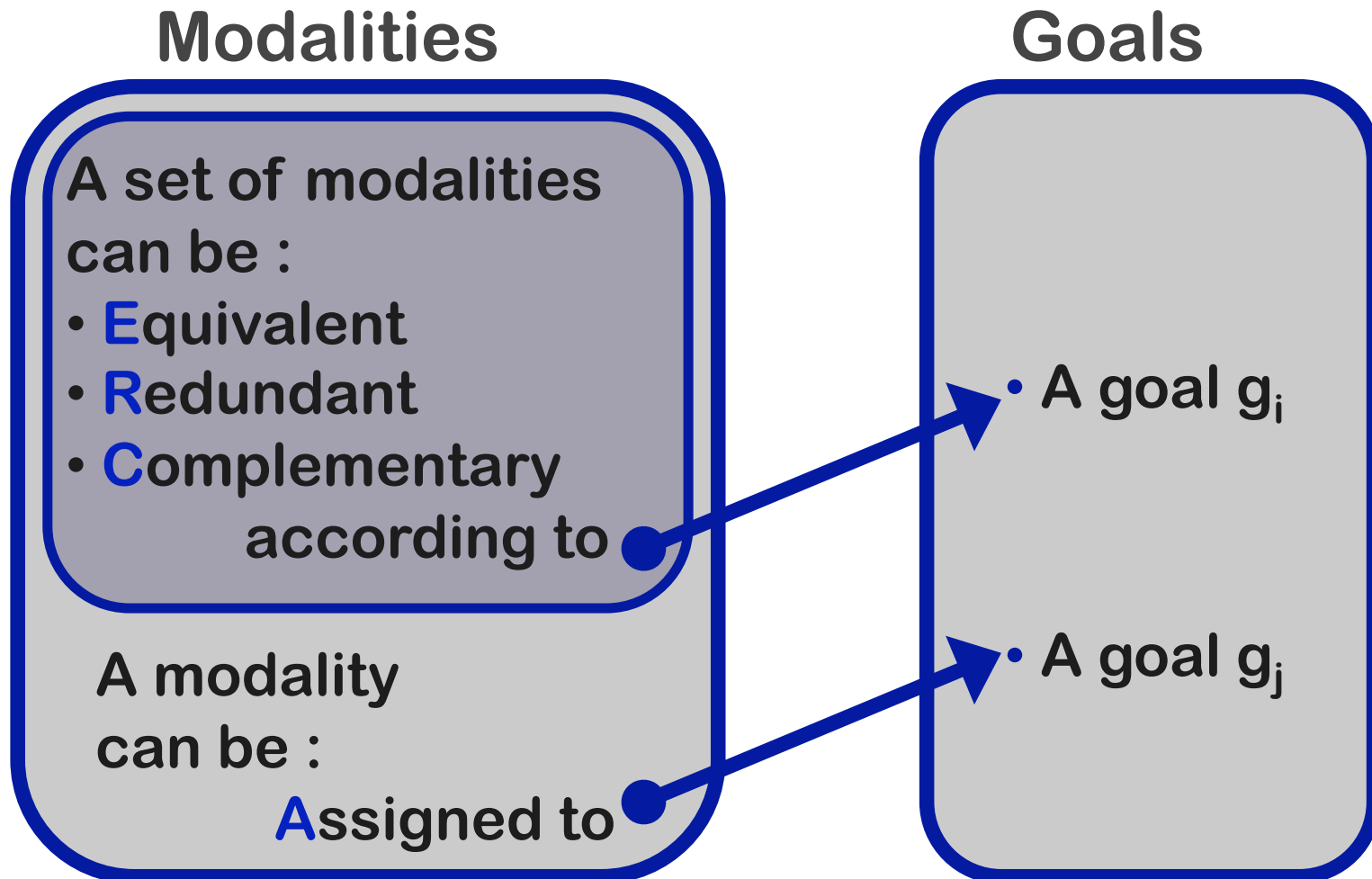

CARE

- Relationships between modalities
 - **A**ssignment: No choice
 - **E**quivalence: Choice
 - **C**omplementarity
 - **R**edundancy
- } Fusion

CARE

- The formal expression of the CARE properties relies on the notions of state, goal, modality, and temporal relationships

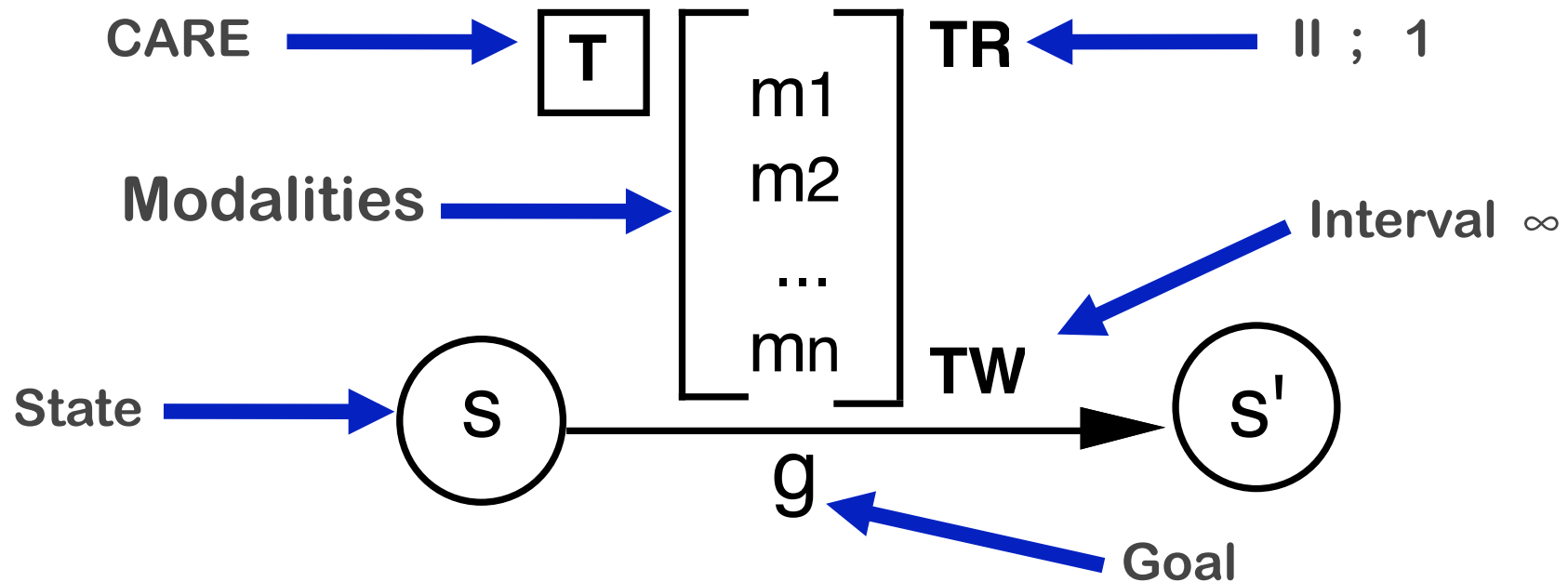

CARE

- Assignment: Absence of choice

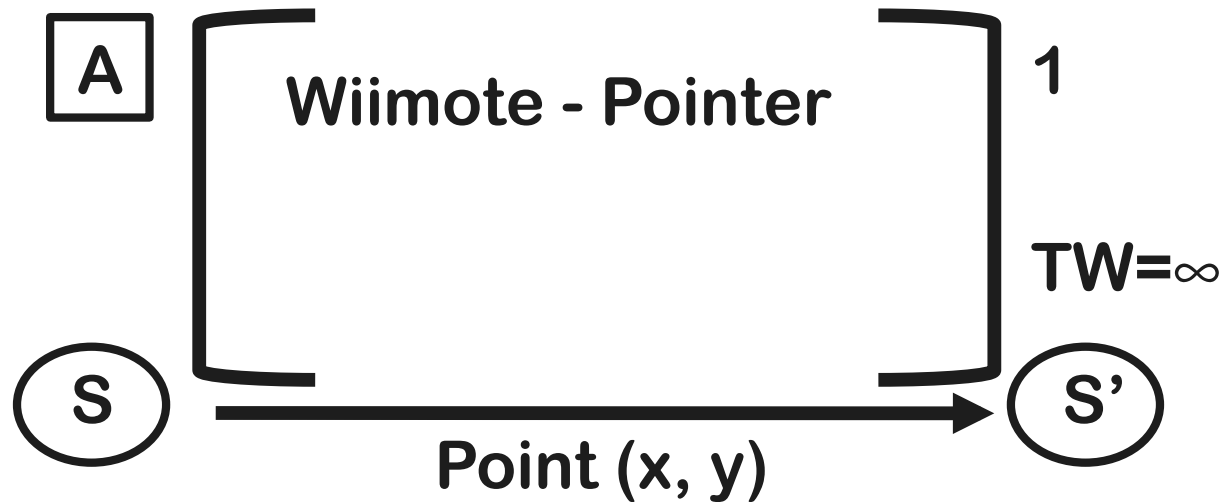
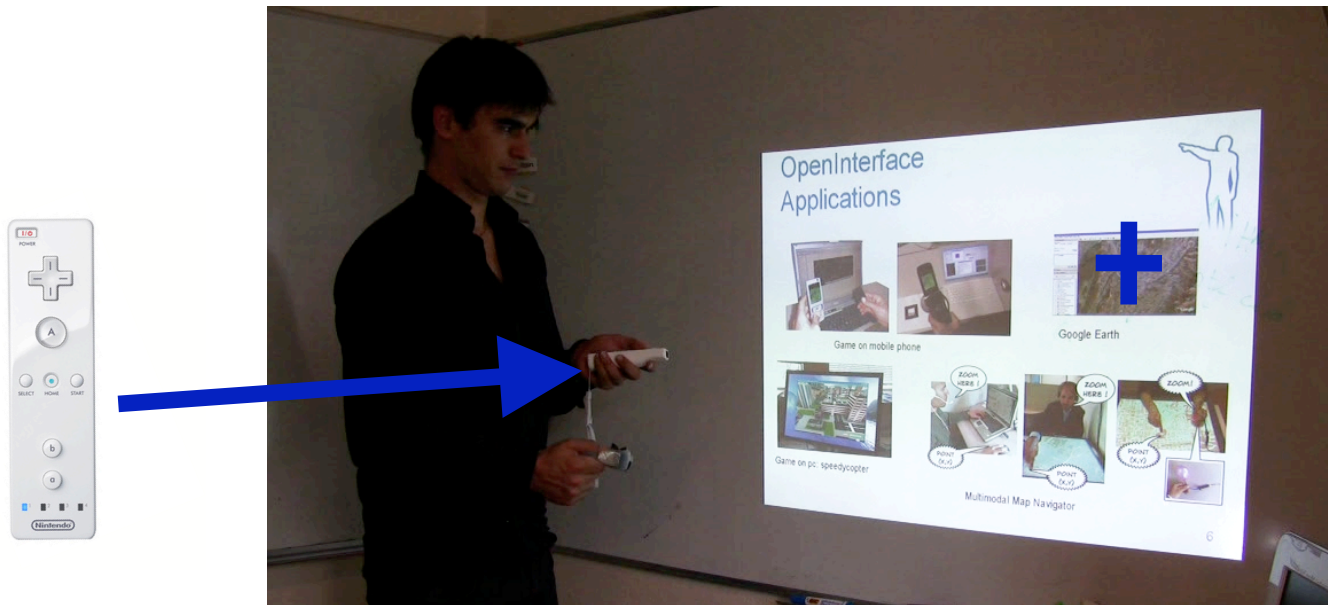

CARE

- **Equivalence: Availability of Choice**

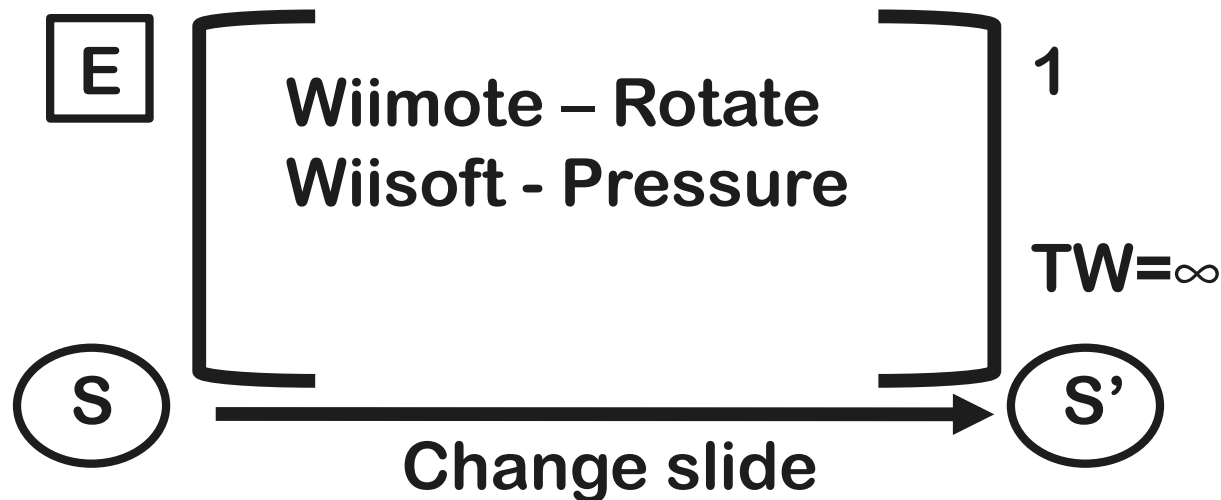
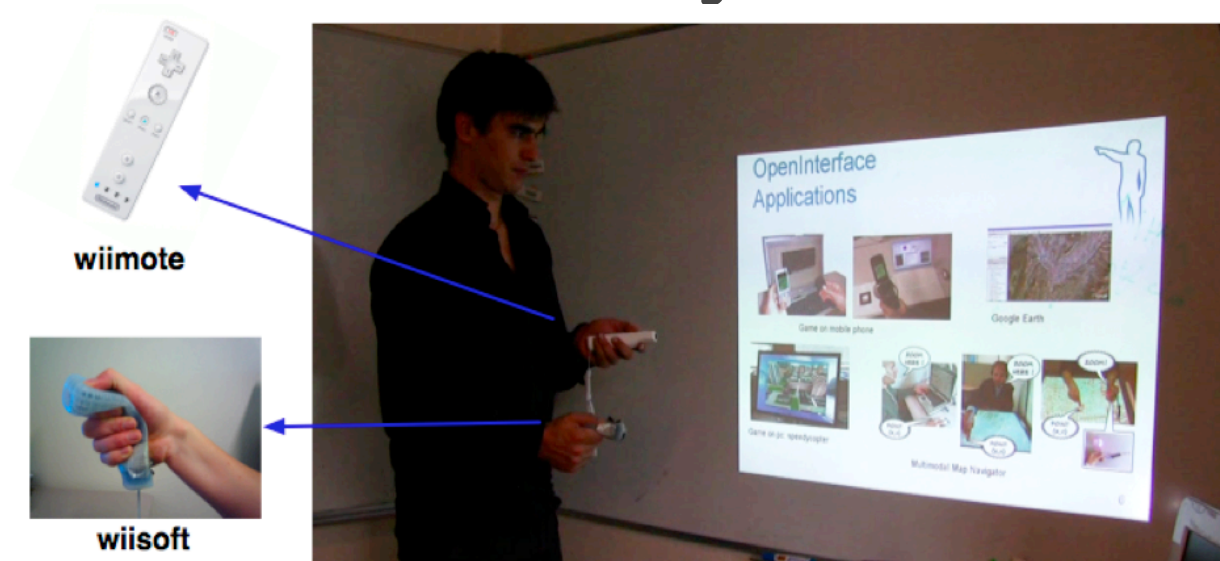

CARE

- **C**omplementarity: Combined use of modalities

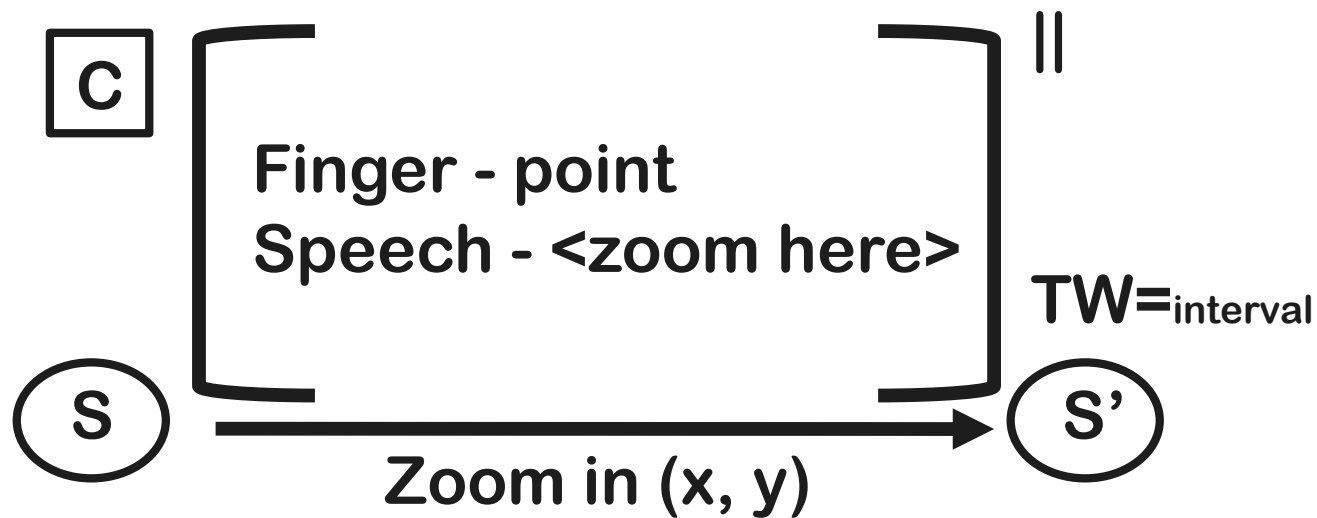

CARE

- **Complementarity: Combined use of modalities**

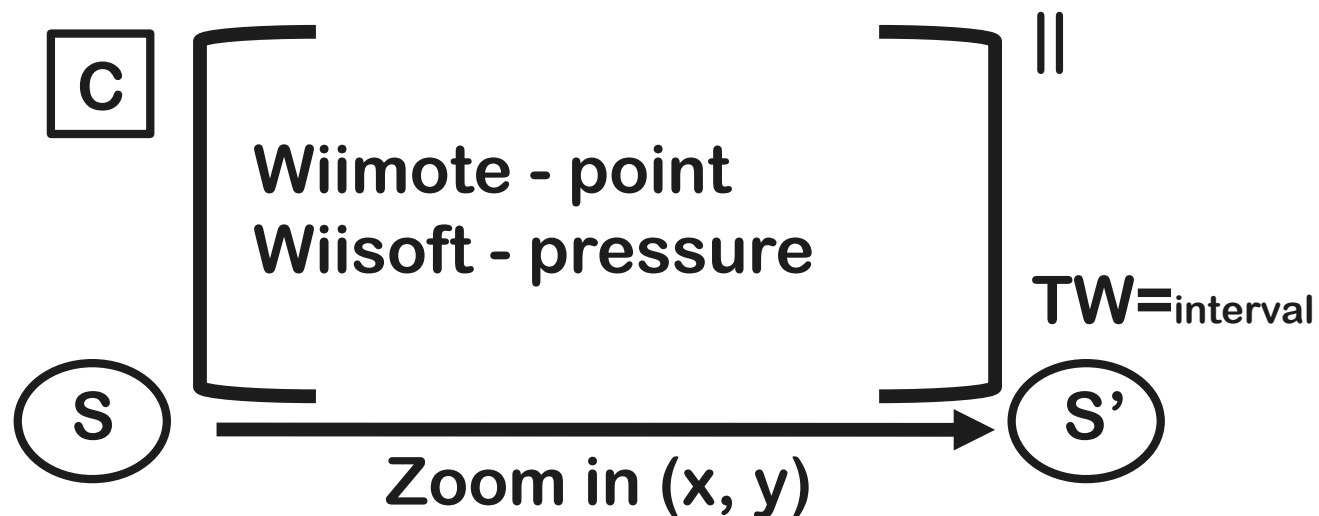
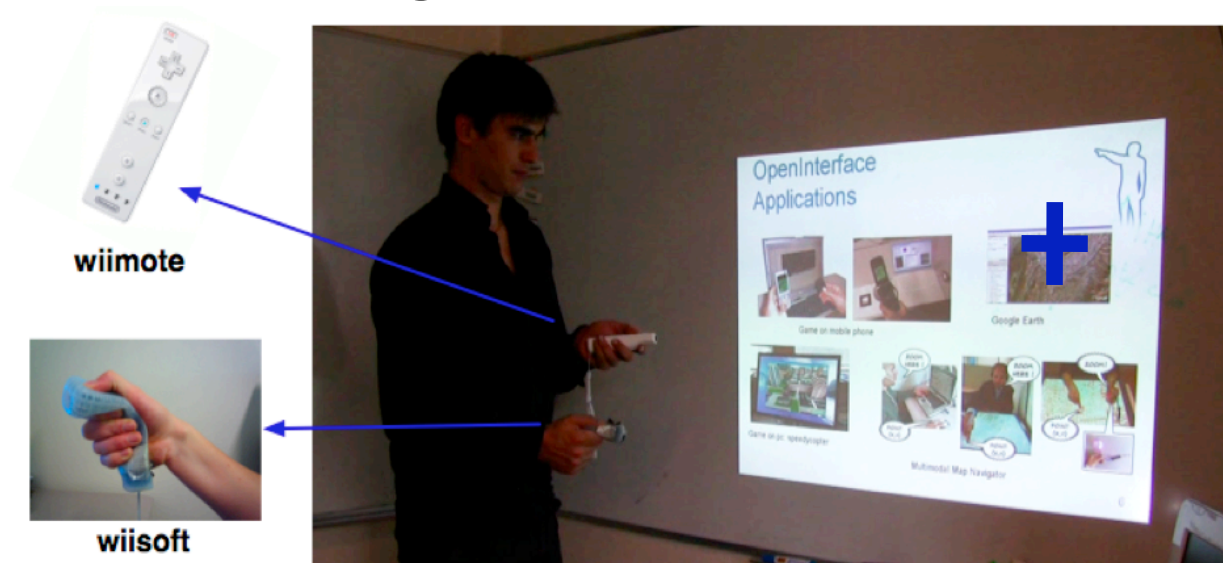

CARE

- Redundancy: Combined use of modalities

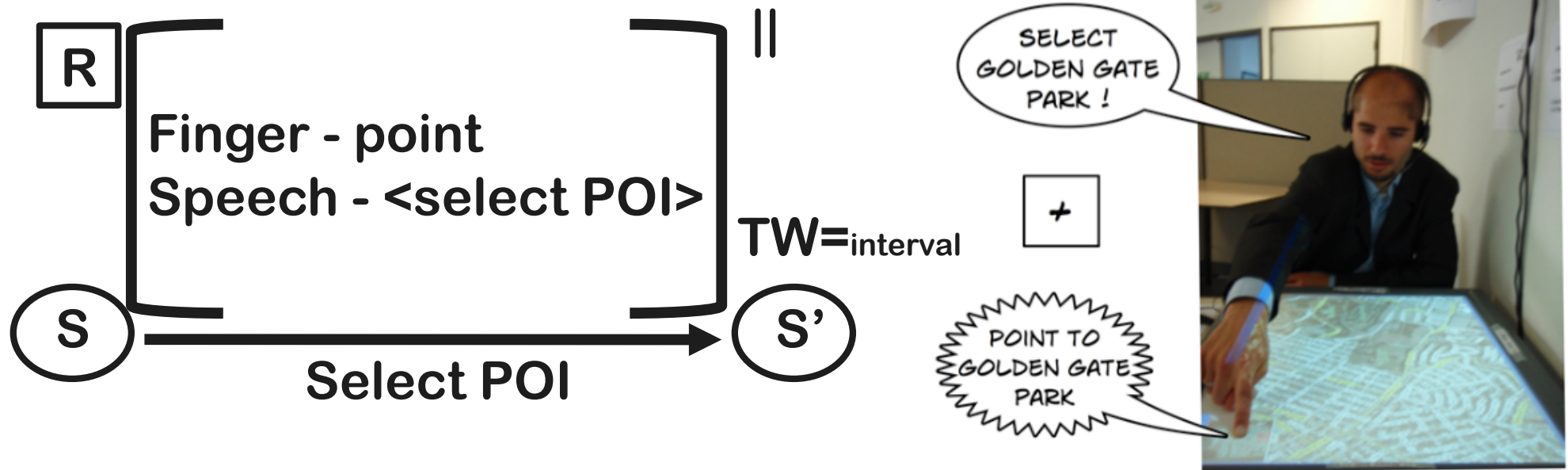

CARE

- **Redundancy: Combined use of modalities**

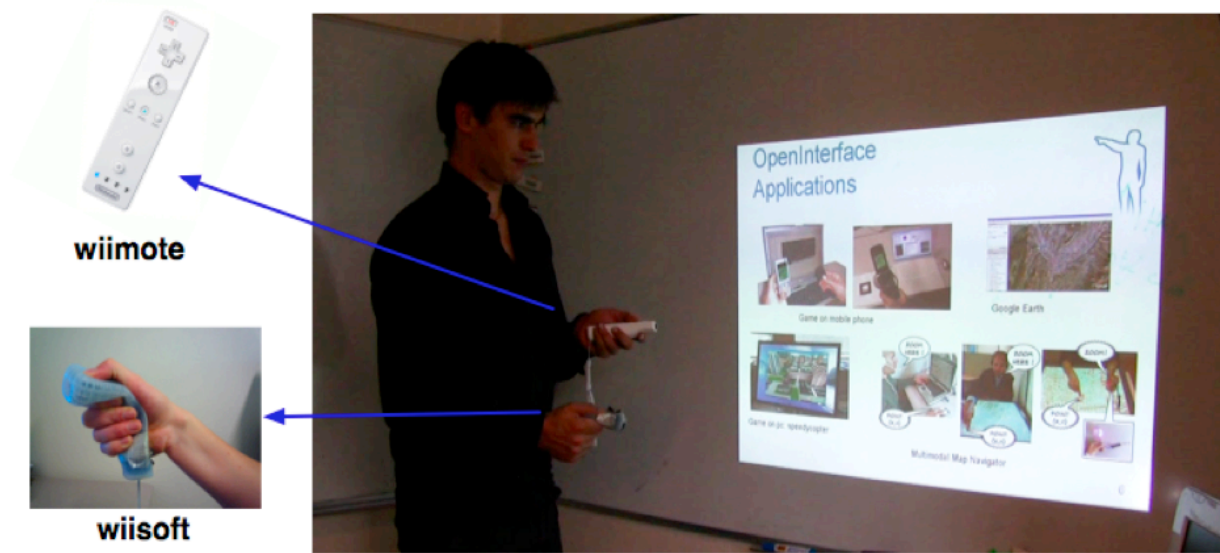

The next slide is reached only if the two actions are performed.

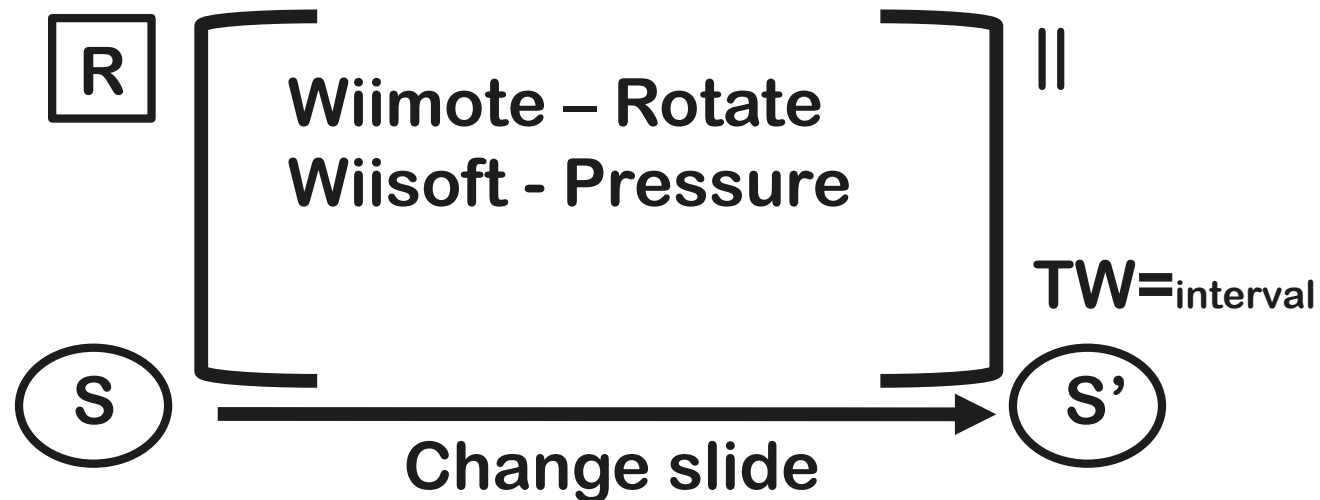

CARE

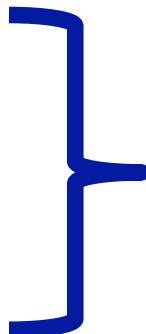
- Relationships between modalities
 - **A**ssignment: No choice
 - **E**quivalence: Choice
 - **C**omplementarity
 - **R**edundancy
- 
- Fusion**

CARE-based fusion

- **C**omplementarity
- **R**edundancy

} **Late fusion**

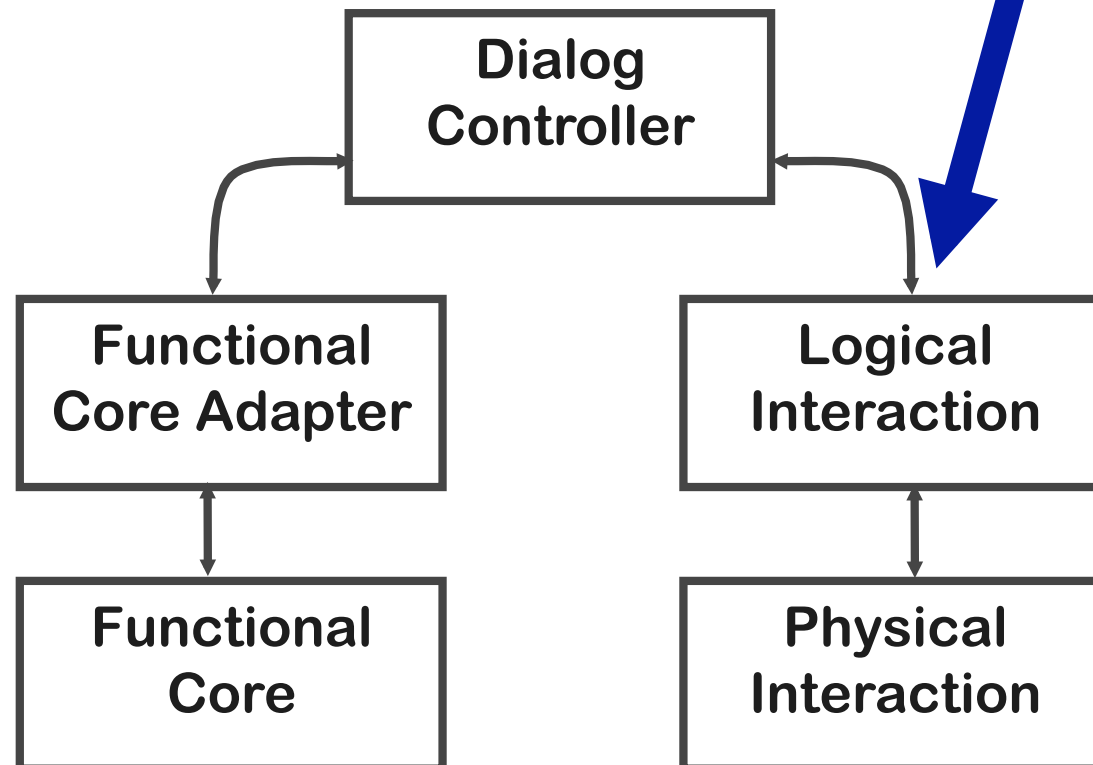

Fusion mechanism: Criteria

- Structural complementarity/redundancy

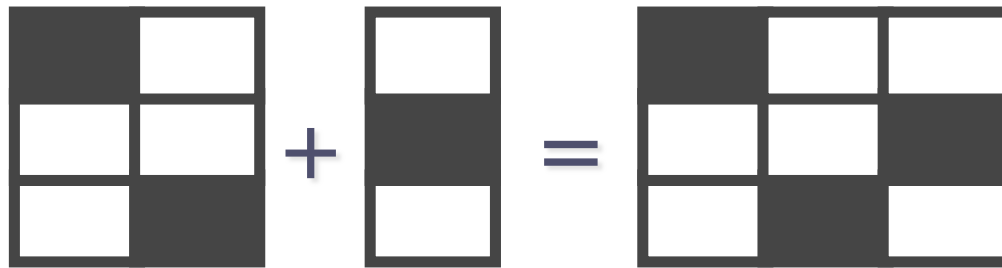

- Time
 - Temporal window

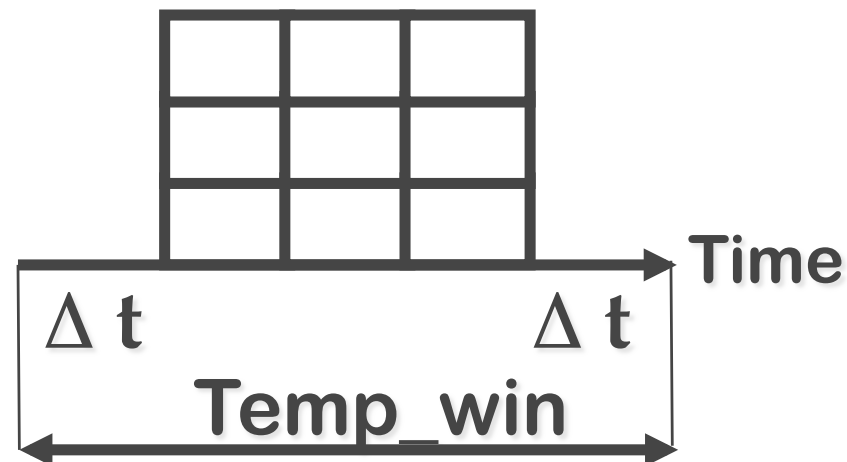

Fusion mechanism

- Complementarity: Zoom in (X, Y)

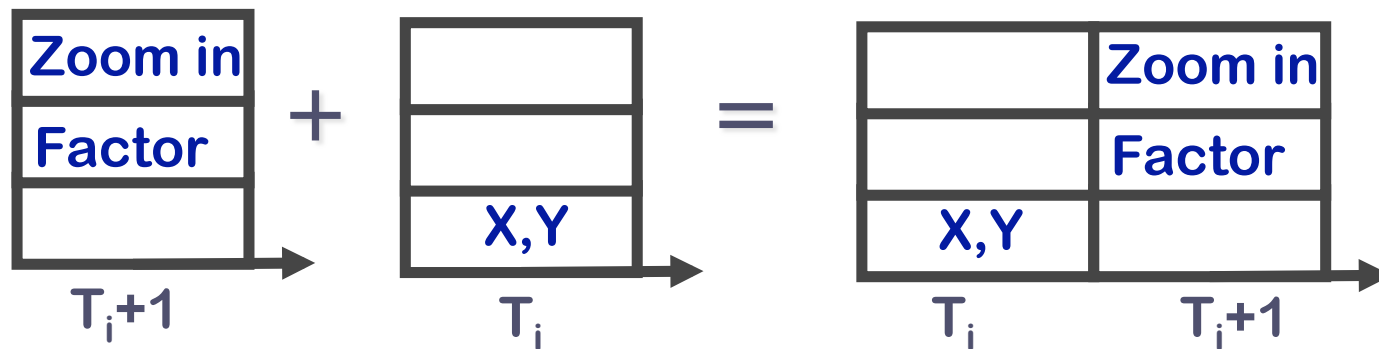
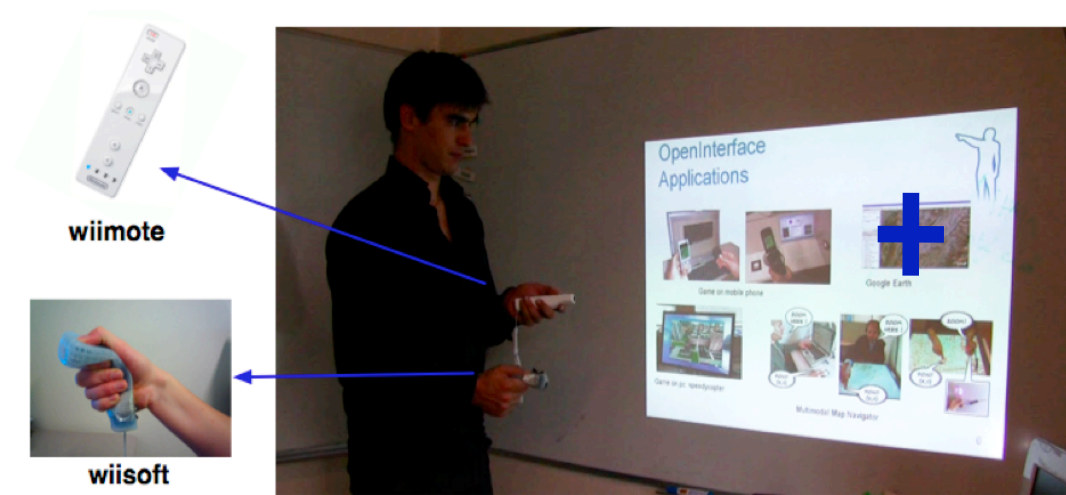

First received

Second received

Fusion mechanism

- Redundancy: Next slide

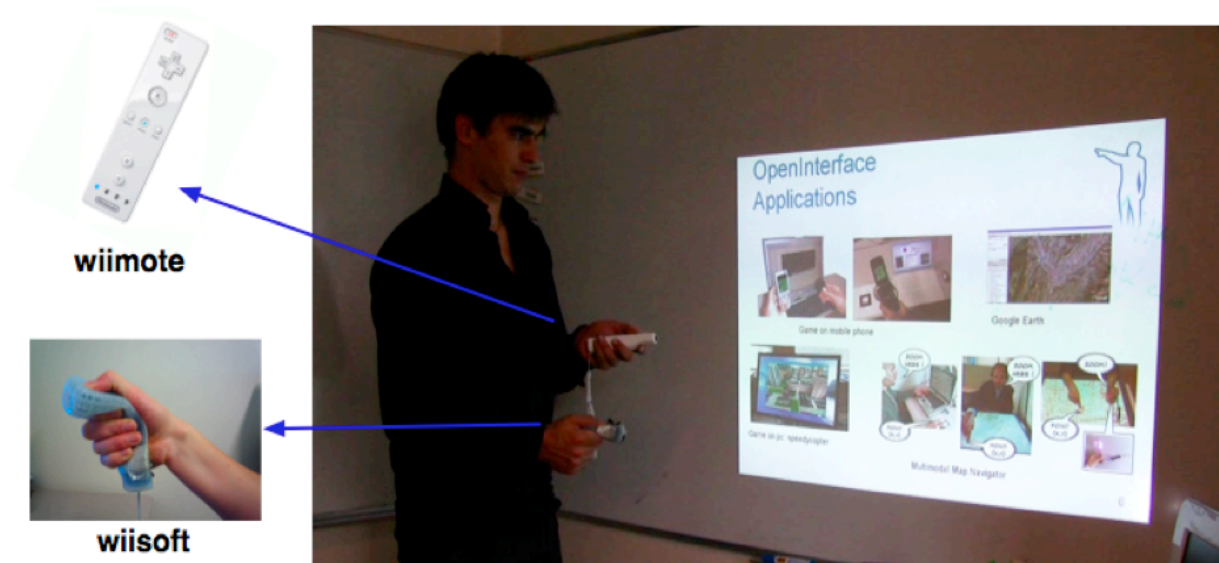

The next slide is reached only if the two actions are performed.

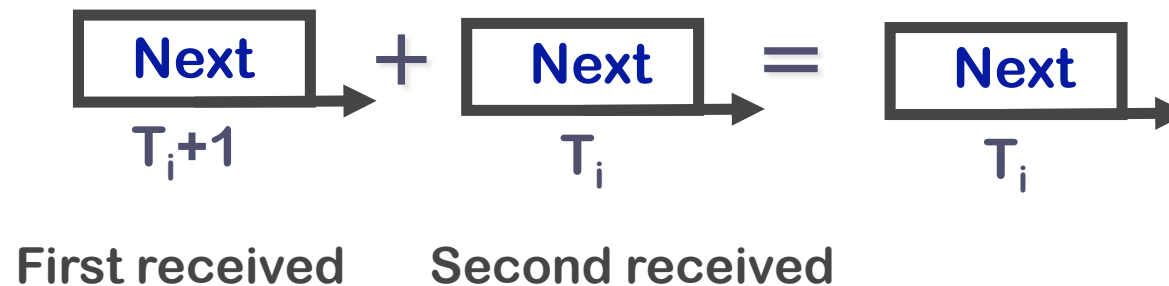

CARE-based fusion

- **C**omplementarity
- **R**edundancy

} **Late fusion**

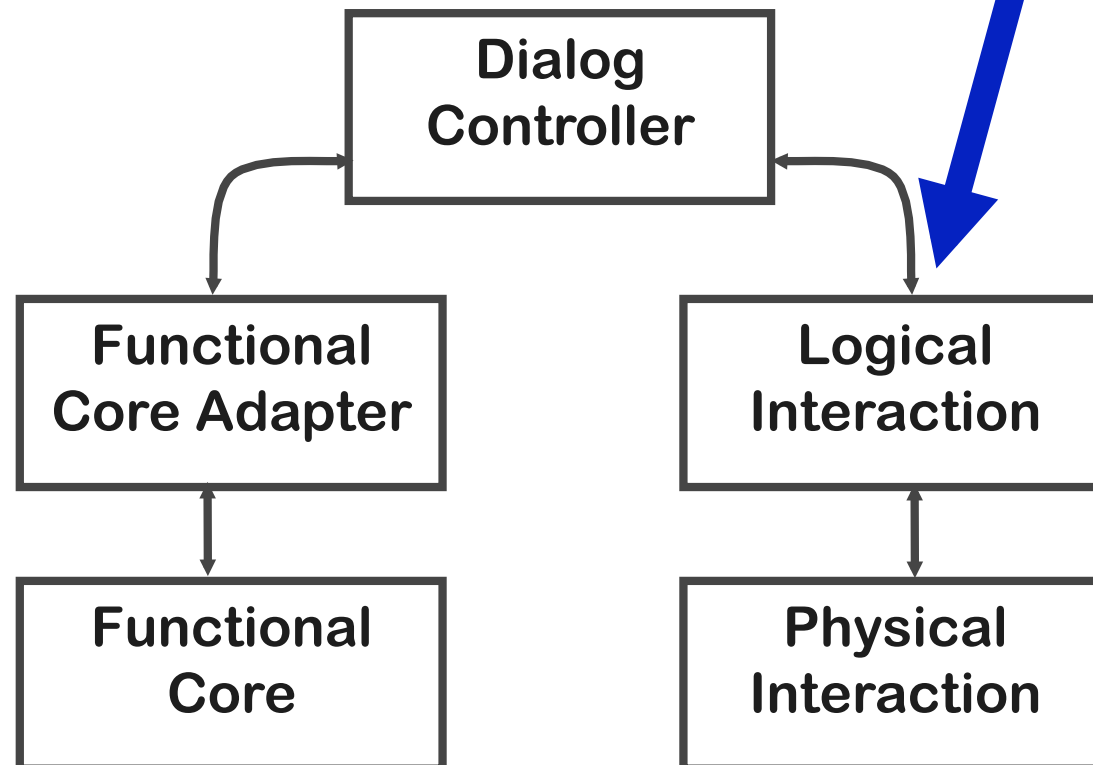

CARE-based fusion

- **Complementarity**
- **Redundancy**

Component-based approach

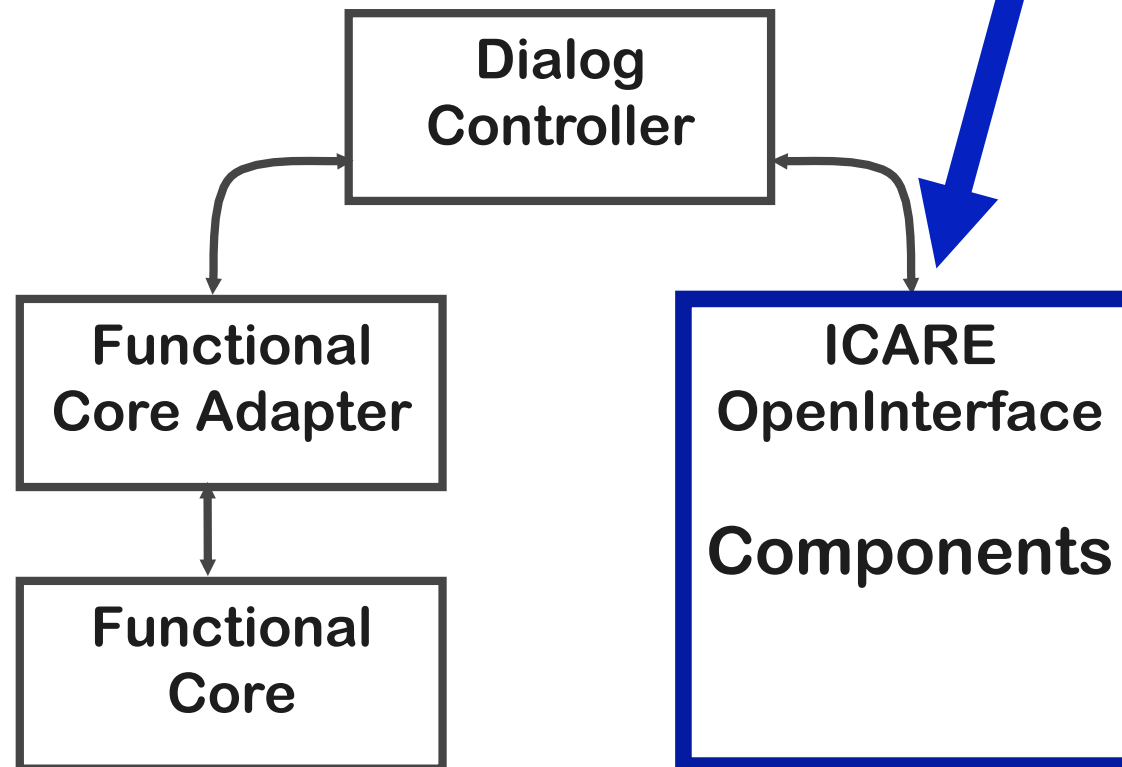

CARE-based fusion

- Complementarity
- Redundancy

Component-based approach

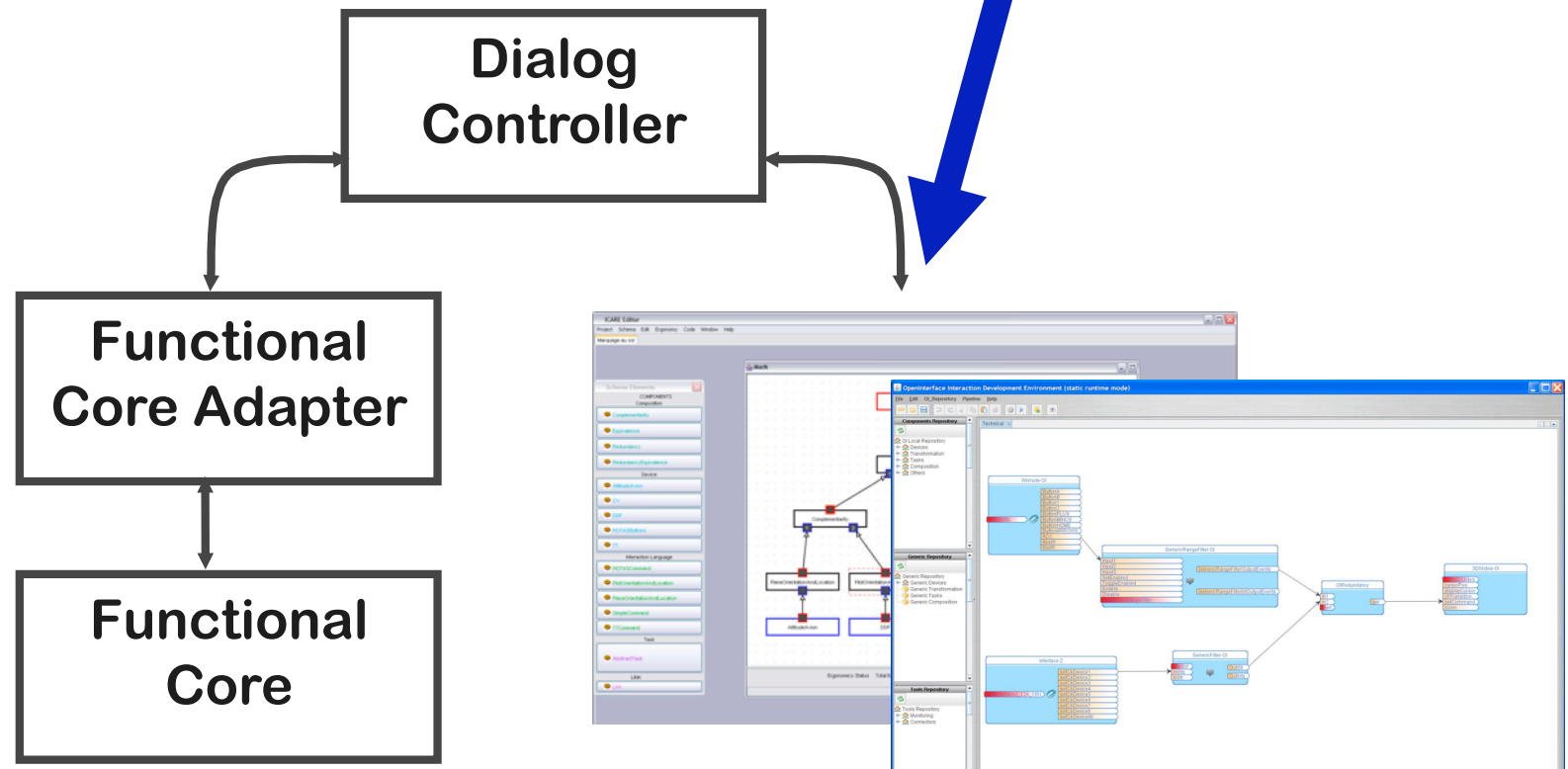

Fusion: component-based approach

- Complementarity: Zoom in (X, Y)

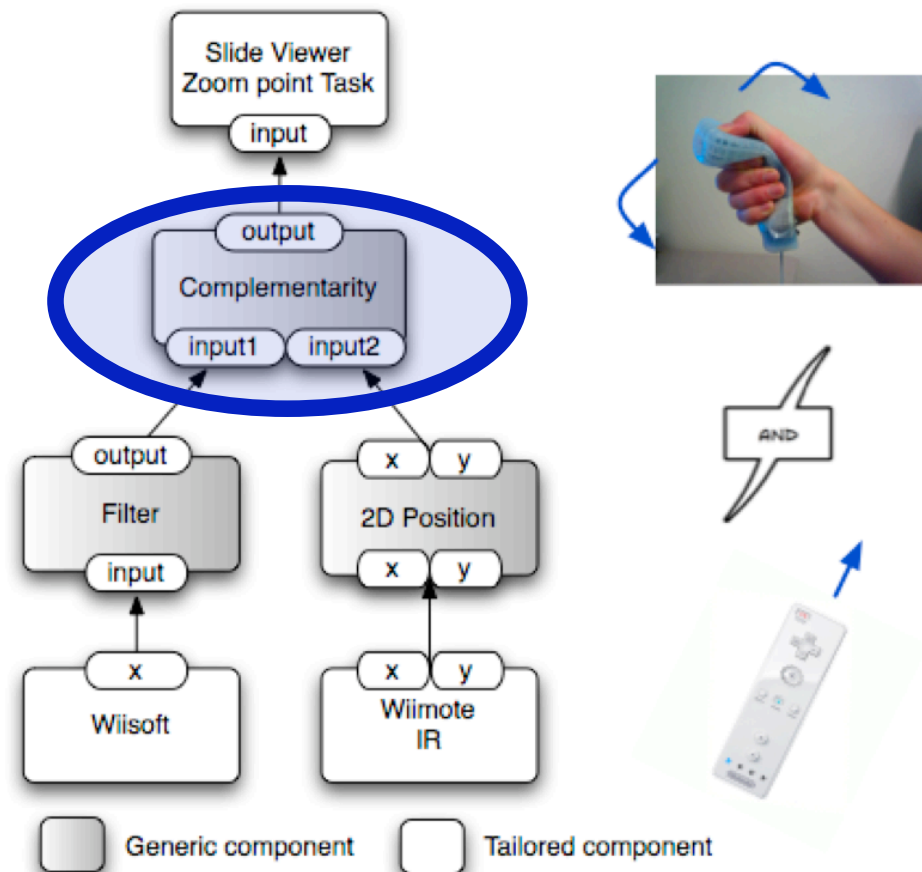
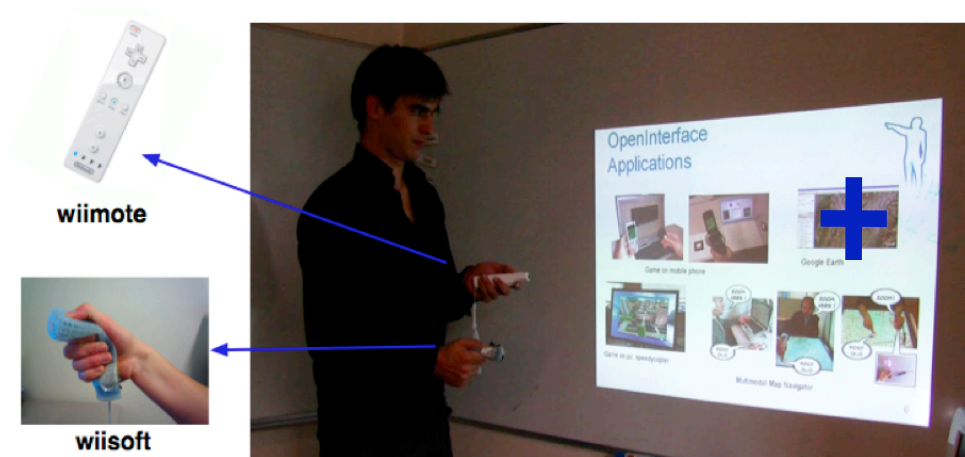

Fusion: component-based approach

- Complementarity: Zoom in (X, Y)

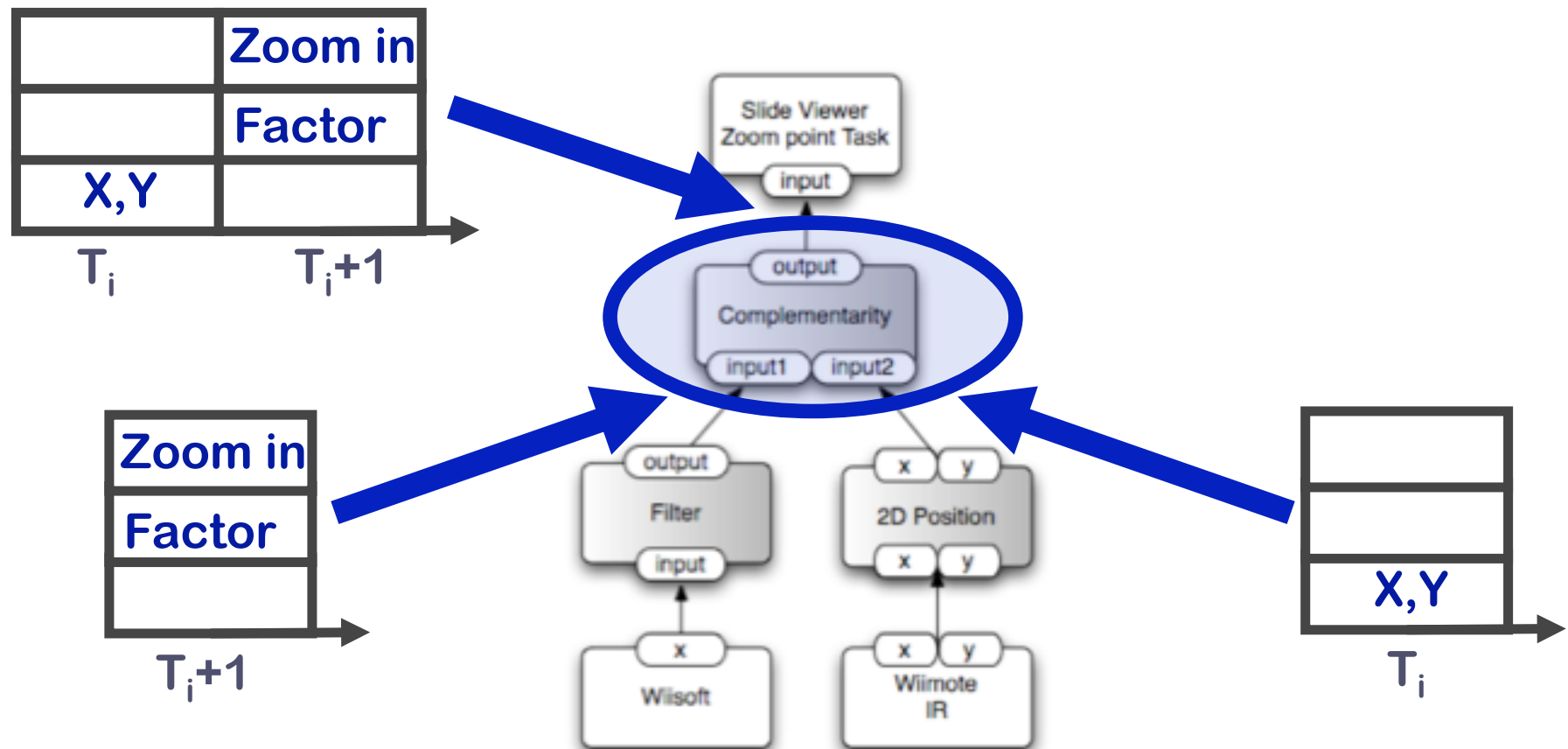

Fusion: component-based approach

- Redundancy: Next slide

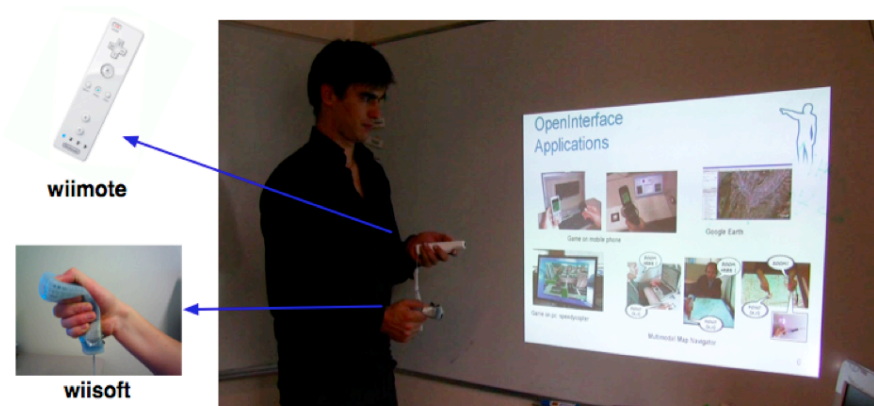

The next slide is reached only if the two actions are performed.

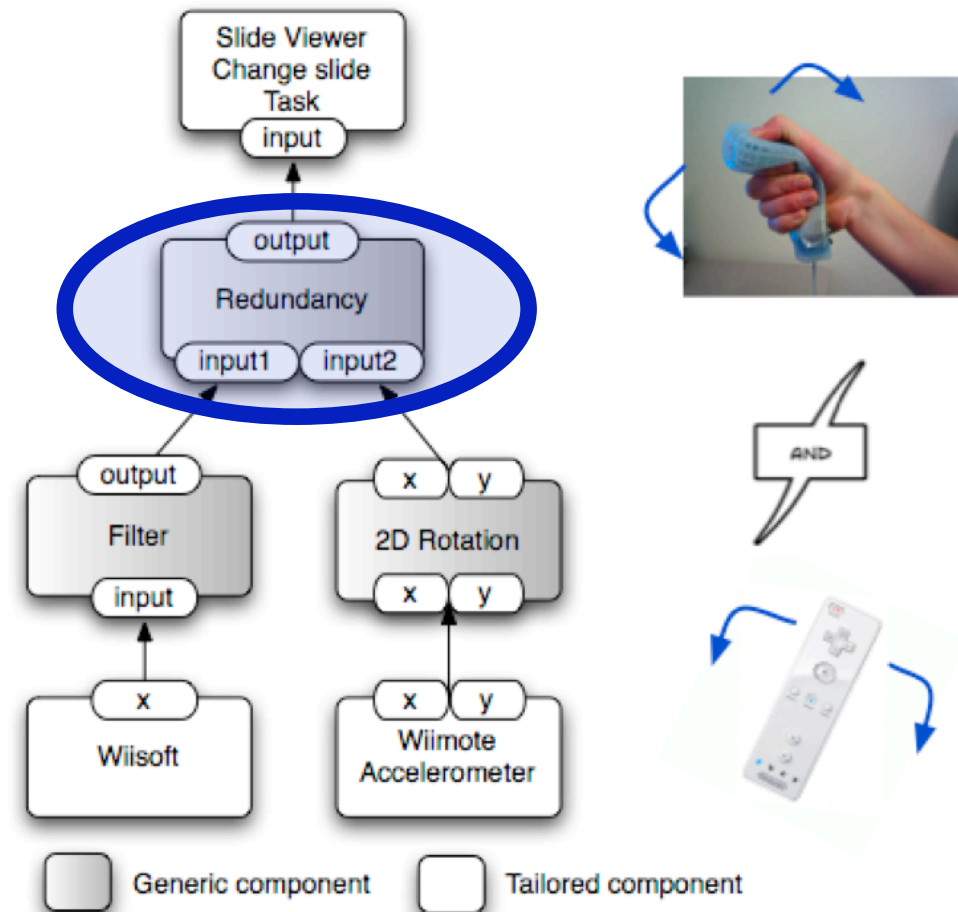

Fusion: component-based approach

- Redundancy: Next slide

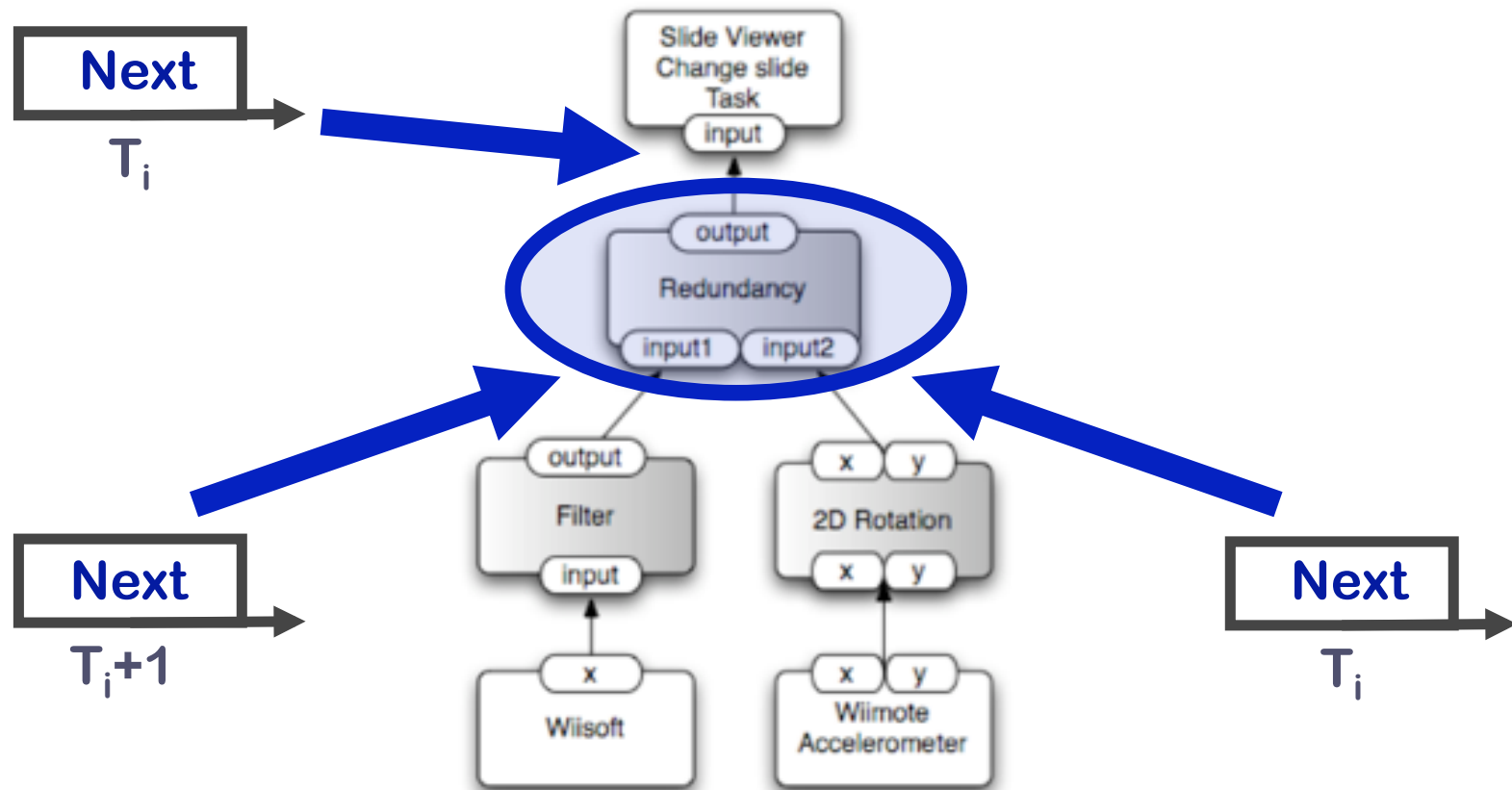

CARE-based fusion

- **Complementarity**
- **Redundancy**

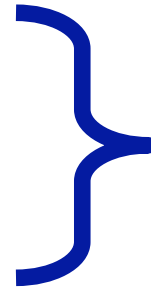

**WoZ
components**

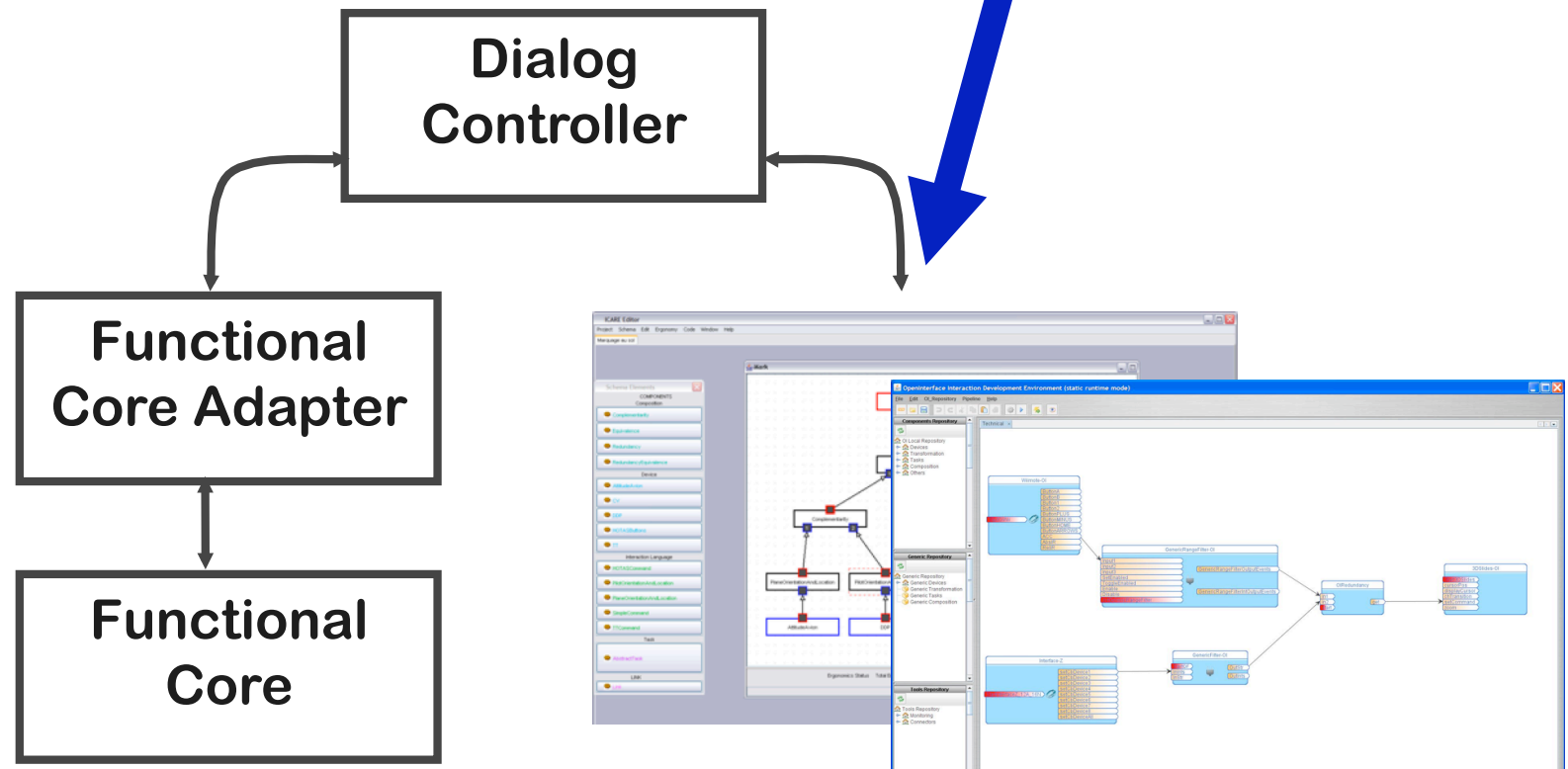

Fusion: WoZ components

- XX

Fusion: WoZ components

- XX

CARE-based fusion: Conclusion

- **Usefulness of the CARE properties**
 - For classifying multimodal systems
 - For guiding usability assessment
 - Given a multimodal system,
how the user will develop her U-preferences?
 - user needs to know what modalities are available
 - user needs to know how to make choice, how to combine modalities
 - For guiding software design
 - Fusion components : Complementarity / Redundancy / WoZ

CARE-based fusion: Future work

- XX – truc sur woz component + des expes
- Decrire ce qui a deja ete fait multiwizard
- En relation avec fusion si possible sinon pas grave

CARE-based fusion



Marcos Serrano
Laurence Nigay

University of Grenoble